

**CHILD RESISTANT 0.5 FL OZ MPAK
70, 100 OR 130MCL DOSAGE**

NUMBER	DOSAGE	SPRAY
ARTV901A-000-1N	70MCL	NARROW
ARTV901A-000-2G	70MCL	WIDE
ARTV901A-000-3N	70MCL	HIGH VISCOSITY
ARTV901B-000-1N	100MCL	NARROW
ARTV901B-000-2G	100MCL	WIDE
ARTV901B-000-3N	100MCL	HIGH VISCOSITY
ARTV901C-000-1N	130MCL	NARROW
ARTV901C-000-2G	130MCL	WIDE
ARTV901C-000-3N	130MCL	HIGH VISCOSITY

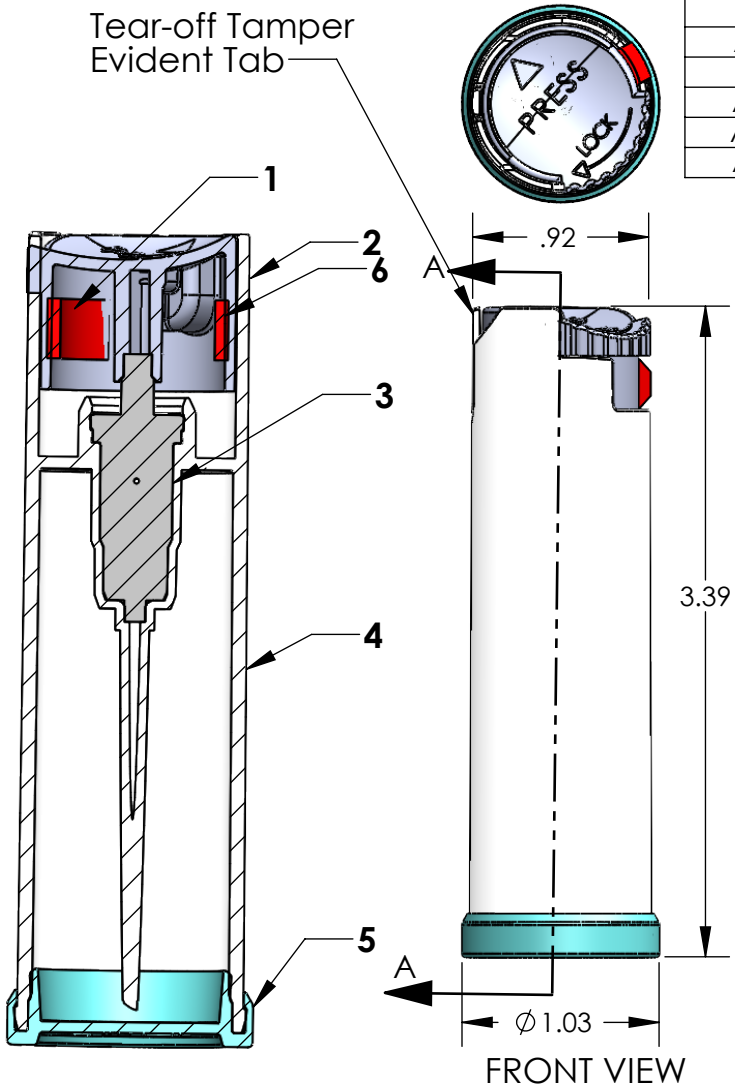

2 PIECE
CHILD
RESISTANT
LOCK
BUTTON

Max Fill
Volume=13ml

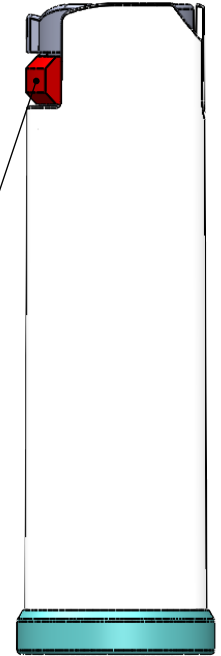

BACK VIEW

TABLE OF RAW MATERIAL USED

ITEM	COMPONENT	PART NUMBER	MATERIAL
1	SPRAY INSERT	PE001	ACETAL
	SPRAY INSERT	PE002	ACETAL
	SPRAY INSERT	PE003	ACETAL
2	ACTUATOR	MA053	ACETAL
	ACTUATOR	MA054	ACETAL
	ACTUATOR	MA055	ACETAL
3	70 mcl PUMP	PD011	SEE DRAWING
	100 mcl PUMP	PD012	SEE DRAWING
	130 mcl PUMP	PD013	SEE DRAWING
4	BODY	MBRV001	POLYPROPYLENE
5	CLOSURE	MC001	POLYPROPYLENE
6	BUTTON	MT	ACETAL



Rev.B Added Max Fill Volume
Rev C. Added 3N Inserts

DIMENSIONS ARE IN INCHES
TOLERANCES:
FRACTIONAL ±
ANGULAR: MACH ± BEND ±
TWO PLACE DECIMAL ±
THREE PLACE DECIMAL ±

	NAME	DATE
DRAWN	HWD	4/14/16
CHECKED		
ENG APPR.		
MFG APPR.		
Q.A.		
COMMENTS:		

PACKAGING CONCEPTS ASSOC., LLC
301 Ella Grasso Avenue
Torrington, Connecticut 06790

MPAK
0.5 FL OZ
CHILD RESISTANT BUTTON
VP4E PUMP

PROPRIETARY AND CONFIDENTIAL
THE INFORMATION CONTAINED IN THIS DRAWING IS THE SOLE PROPERTY OF PACKAGING CONCEPTS ASSOCIATES. ANY REPRODUCTION IN PART OR AS A WHOLE WITHOUT THE WRITTEN PERMISSION OF PACKAGING CONCEPTS ASSOCIATES IS PROHIBITED.

NEXT ASSY	USED ON	FINISH
APPLICATION		DO NOT SCALE DRAWING

SIZE	DWG. NO.	REV.
A	ARTV901 Customer Model	C
SCALE:1:1	WEIGHT:	SHEET 1 OF 1